



Gas Detector



Safe Area Fixed Gas Detector



Installation, Operation & Maintenance

Please read this manual carefully and retain for future use.

OGS supply a range of remote gas detectors including carbon monoxide (CO), natural gas/methane (NG), liquid petroleum gas (LPG) and also oxygen (O₂) that are compatible with our range of Merlin control panels connecting up to 12 detectors (control panel dependant) per cable run to monitor gas levels/hazards in safe areas.

-  *The information contained within this manual should be referenced for typical installation and operation only.*
-  *For specific requirements that may deviate from the information in this manual – contact your supplier.*

Contents

Important Warning Statements	3
Installation	4
Typical Location & Positioning	4
Access & Mounting.....	4
Internal Board Overview	5
Wiring the Detector.....	5
BMS Output.....	5
Audible Alarm Switch	6
Trouble Shooting	6
Operation	6
Initial Power-Up (Commissioning).....	6
Alarm Set Points	6
General Maintenance	7
Cleaning	7
Manual Circuit Simulation Test	7
Bump Test (Gas Response Check)	7
End of Operational Life (EOL)	8
Specification	9



Important Warning Statements

Please take the time to thoroughly read these instructions which should be retained for future reference.

Detectors are shipped pre-calibrated and configured.

The expected lifetime of a gas sensor is 3-10 years upon initial power up dependant on your target gas and environmental factors. The device will display a message to indicate this time and should immediately be replaced.

It is recommended that this device be commissioned upon installation and serviced annually by a competent person.

Do not apply lighter gas or other aerosols to the device – this will cause extreme damage to the sensors.

High concentrations of alcohol found in many products may damage, deteriorate or affect the gas sensing elements.

This device is designed to detect the gas type displayed on the screen only.

It is not designed to detect smoke, fire or other gases and should not be used as such.

This device provides early warning of the presence of gas, usually before a healthy adult would experience symptoms.

This warning is possible provided your alarm is installed and maintained in accordance with this manual.

Never ignore your device when in alarm.

This device requires a continual supply of electrical power – it will not work without power.

This device should not be used to substitute proper installation, use and/or maintenance of fuel burning appliances including appropriate ventilation and exhaust systems.

Multiple detectors may be required to adequately protect property and persons.

This device does not prevent dangerous gasses from occurring or accumulating.

Actuation of your alarm indicates the presence of dangerous levels of gas.

The device is not intended for use in potentially explosive atmospheres.

Seek fresh air supply and contact your local gas emergency service should you suspect a gas leak.

This unit may not fully safeguard individuals with specific medical conditions. If in doubt, consult a doctor/physician.

Your product should reach you in perfect condition, if you suspect it is damaged, contact your supplier.

Manufacturer's Warranty

Warranty coverage: The manufacturer warrants to the original consumer purchaser, that this product will be free of defects in material and workmanship for a period of three (3) years from date of purchase or one (1) years for oxygen detectors.

The manufacturer's liability hereunder is limited to replacement of the product with repaired product at the discretion of the manufacturer. This warranty is void if the product has been damaged by accident, unreasonable use, neglect, tampering or other causes not arising from defects in material or workmanship. This warranty extends to the original consumer purchaser of the product only. **Warranty disclaimers:** Any implied warranties arising out of this sale, including but not limited to the implied warranties of description, merchantability and intended operational purpose, are limited in duration to the above warranty period.

In no event shall the manufacturer be liable for loss of use of this product or for any indirect, special, incidental or consequential damages, or costs, or expenses incurred by the consumer or any other user of this product, whether due to a breach of contract, negligence, strict liability in tort or otherwise. The manufacturer shall have no liability for any personal injury, property damage or any special, incidental, contingent or consequential damage of any kind resulting from gas leakage, fire or explosion. This warranty does not affect your statutory rights. **Warranty Performance:** During the above warranty period, your product will be replaced with a comparable product if the defective product is returned together with proof of purchase date. The replacement product will be in warranty for the remainder of the original warranty period or for six months – whichever is the greatest.

Information on waste disposal for consumers of electrical & electronic equipment.



When this product has reached the end of its life it must be treated as Waste Electrical & Electronics Equipment (WEEE).

Any WEEE marked products must not be mixed with general household waste, but kept separate for treatment, recovery and recycling of the materials used. Please contact your supplier or local authority for details of recycling schemes in your area.

At the end of their working life, electrochemical sensors for oxygen and carbon monoxide detectors should be disposed of in an environmentally safe manner. Alternatively they can be securely packaged and returned to OGS clearly marked for disposal. Electrochemical sensors should not be incinerated as this may cause the cell to emit toxic fumes.

Installation

Typical Location & Positioning

Our detectors should be installed in safe areas only at risk of gas leaks e.g. over boilers, valves or meters. Take in to account the design of the air flow patterns within the zone area. Detectors should be installed in the correct orientation, as recommended, and ease of access should be accounted for to allow for any servicing, recalibration and other forms of maintenance. Consider the coverage required, application and function of the area. Emphasis should be placed on airflow patterns, correct placement and not perceived detection ranges. The target gas will only be identified when contact is made with the sensing element itself.

Maximum Gas Detectors per Merlin Panel

Merlin 'S' Range	1 Detector
Merlin GDP2	6 Detectors (2 Zone Panel – LED Indication)
Merlin GDP4	12 Detectors (4 Zone Panel – LED Indication)

Avoid conditions of any other environmental factors that could potentially impede the accuracy and operation of the detectors such as; condensation; vibration; temperature, pressure, the presence of other gases, electromagnetic interference and draft/splash zones i.e. doors, fans, sinks, ovens etc.

Locations for detectors will vary based on the intended application and target gas, they should be located near identified sources of a potential gas leaks/pockets where gas could quickly accumulate and areas of identified consequential risk to detect gas. The composition of the target gas and its density relative to air are used as the basis for the recommended height of sensors. Generally, the installation height of a sensor for a heavy gas (such as propane) would be close to the lowest point in the area, and for a light gas (such as methane) would be close to the highest point in the area. These recommended heights may vary based on air flow and temperature conditions in addition to the proposed application and location – this is particularly apparent with oxygen depletion sensors, and the target gas that they are used for.

Target Gas

Natural Gas/Methane (NG)
Liquid Petroleum Gas (LPG)
Carbon Monoxide (CO)
Hydrogen (H)
Oxygen (O₂)

Typical Position

High Level - 300mm (1ft) from ceiling
Low Level - 300mm (1ft) from ground level
Breathing Zone - 1700mm (5ft 6") from ground level
High Level - 300mm (1ft) from ceiling
*Breathing Zone - 1000-1500mm (3 - 5ft) from ground level

* If you are installing and monitoring Oxygen depletion – consider the density of gas for its application and position the detector accordingly i.e. ground level for high density gases.

The detectors are designed around a centralised control panel of which the location also needs to be considered. The control panel should be located away from the area that it is monitoring and accessible is for both status observation and alarm purposes.

Access & Mounting

Unpack all the parts.

The detectors are designed for surface mounting and must be installed by a licensed, insured contractor or competent person. A deeper back enclosure is supplied to accommodate wiring where required.

Carefully remove the rear cover from the unit by unscrewing the hex screws located at the bottom of the case. To do this – use the socket wrench provided.

Using the rear cover - mark the screw holes to the wall and ensure the wall surface is flat to prevent base distortion. There are two pre-fractured areas for cable entry provided on the inside of the rear cover which may be cut away as required. After executing the mounting and the connections – replace the rear cover.

Make a note of the installation date on the label located on the side of the unit.

We recommend all Merlin gas detection equipment is commissioned by a competent/trained engineer to ensure correct installation and operation. Contact OGS for more information.

Internal Board Overview

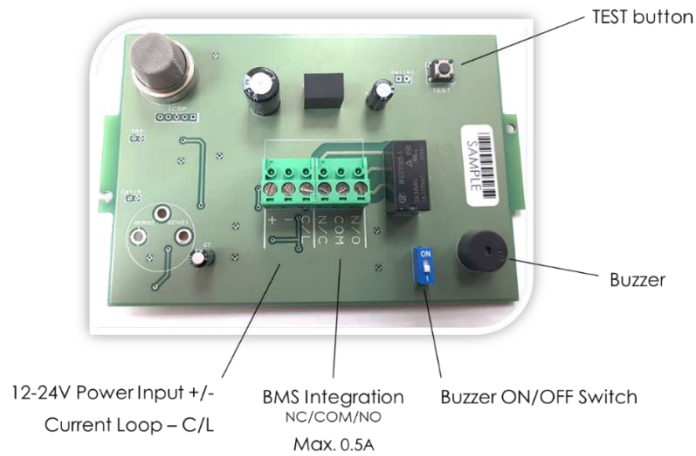

**Be careful when creating access for cables – Damage to circuit boards will void any warranty!
Any damage attempting to remove the circuit board parts may void any warranty!**

Wiring the Detector

S-Panel (1000S / 1000SW+ / 1500S etc.)

Power is supplied to a detector via the GDP terminal [+ / -] and using the ‘S’ panel [GAS DETECTOR] terminal [+ / -]. For a BMS alarm relay use [COM] and [NC] on the detector and the [open/close] switch terminal on the panel.

GDP Panel (GDP2 / GDP4)

Power is supplied to a detector via the GDP terminal [+ / -] and using the panel [GAS DETECTION ZONE] terminal. If you are using a GDP panel you will need to use the detector [C/L] terminal as an alarm relay.

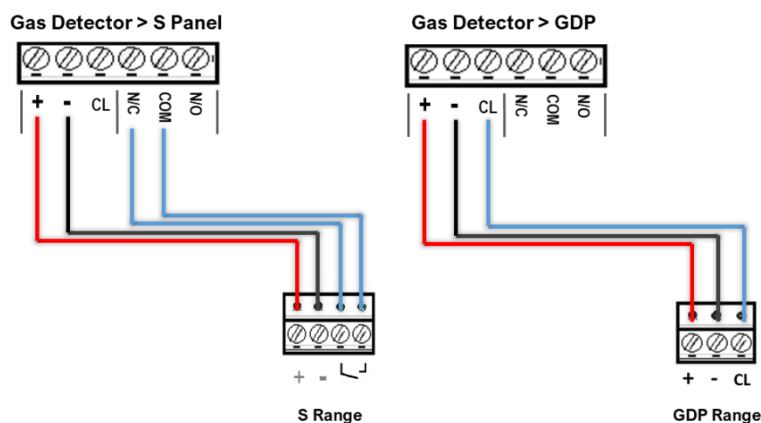

BMS Output

If you are connecting to Merlin ‘S’ range you will need to use [NC/COM] terminals as an alarm relay. These are volt free connections to building management systems.

If you are using our ‘GDP’ range you will need to use the [C/L] terminal as an alarm relay. A relay will change state when in alarm or when gas is detected.

BMS terminals can be used in conjunction with other external relays that affect other devices and controls such as purge fans and audible alarms etc.

Audible Alarm Switch

There is a switch on the Detector circuit board.

The user can choose whether to have an audible alarm when dangerous gas levels are detected. The alarm will continuously sound – there are no provisions to silence the alarm, gas levels must drop to a safe value for the alarm to stop.

Trouble Shooting

Fault.	Possible Cause/Correction.
Detector not responding.	<ul style="list-style-type: none"> ○ Incorrect wiring. ○ Exceeded zone detector capacity. ○ Sensor exceeded expected life span.
LED flashing and alarm beep.	<ul style="list-style-type: none"> ○ Sensor fault. Contact your supplier

Operation

Initial Power-Up (Commissioning)

On connecting power, the detector enters 'sensor stabilisation' phase for approximately 60 seconds – during this period the device is not yet ready for gas detection.

- **Power**
Detector powered. Green LED is on.
- **Low (Attention!)**
Detector reached Pre-alarm gas level. Amber LED is on.
- **High (Danger!)**
High concentration of gas detected, buzzer sounds. Red LED is on.

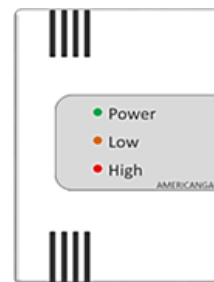

⚠ **High** - If the High LED flashes and buzzer beeps, there is a fault – contact your supplier.

Alarm Set Points

▲ Rising alarm ▼ Falling alarm LEL (Lower Explosive Limit) PPM (Parts per Million)

Gas Detector	Pre-Alarm	Buzzer	Alarm State	Buzzer
Methane/Natural Gas (NG)	▲ 8% LEL	No Sound	▲ 10% LEL	Continuous sound
Liquid Petroleum Gas (LPG)	▲ 8% LEL		▲ 10% LEL	
Hydrogen Gas (H)	▲ 8% LEL		▲ 10% LEL	
Oxygen (O2)	N/A		▼ 18.5% ▲ 23%	
Carbon Monoxide (CO)	▲ 20 PPM		▲ 20ppm after two (2) hours ▲ 50ppm after One (1) hour ▲ 100ppm after Ten (10) minutes ▲ 300ppm after One (1) minute	

⚠ **An audible buzzer will sound if the buzzer switch on the circuit board is on!**

General Maintenance

Cleaning

Keep your gas detector in good working order - follow these basic principles;

- Remove any dust/debris from the outer enclosure regularly using a slightly damp cloth.
- Never use detergents or solvents to clean your device.
- Never spray air fresheners, hair spray, paint or other aerosols near the device.
- Never paint the device. Paint will seal vents and interfere with the device.



Concentrations of alcohol found in many products may damage, deteriorate or affect the gas sensing elements such as; wine; deodorants; stain removers and thinners. Other gases and substances to avoid are; corrosives (i.e. chlorine & hydrogen chloride); alkali metals; basic or acidic compounds; silicones; tetraethyl lead; halogens and halogenated compounds!

Manual Circuit Simulation Test

When the test button on the circuit board is pressed and held for ~3s the detector will simulate an open circuit to ensure outputs, alarms, indications and external devices etc. operate as intended in response to gas.



Access to the interior of the detector, when carrying out any work, must be conducted by a competent person! This test does not check the gas sensing element itself!

Bump Test (Gas Response Check)

What is a Bump Test?

Gas response checks are often referred to as a 'bump test'. Bump tests are important to make sure a device is able to detect a release of gas as early as possible. The aim of the bump test is to make sure a detector is working at its optimum by briefly exposing the unit to a known concentration of the target gas that usually exceeds the highest alarm point. If the detector goes into alarm and all signals/outputs activate, then the system is working safely. If the system fails to operate as intended in an alarm state, the gas detector must not be used until a full inspection and service has been conducted.

Why is it important?

A detector may visually appear in good working order, but its sensitivity can be inhibited by external factors. Dust, humidity, temperature fluctuations, cleaning products, contaminants or sensor drift (ageing) can cause a decline in sensitivity and eventual failure.

How often?

Regular bump tests are important to make sure the detector is able to detect a release of gas as early as possible and usually takes seconds (gas type dependant i.e. CO sensors will take over a minute) and is often completed alongside a scheduled fire alarm test, however the frequency should be determined following an appropriate risk assessment by the end user. Remember, bump testing does not remove the need to have gas detectors inspected, calibrated and serviced periodically by a competent person.

What do I need?

Contact your OGS representative for details of suitable bump testing kits and gases. Kits usually consist of a certified gas cylinder; flow control regulator, tube pipe and applicator cone. We recommend only using OGS calibration gas kits to ensure correct flow rates meet OGS technical requirements. A bump testing gas is usually a concentration mix that exceeds the highest alarm set point.

See below for recommended gas concentrations for bump testing your detector.

<u>Detector Type</u>	<u>Bump Test Gas</u>	<u>Response Time</u>
CO - Carbon Monoxide	400 - 500ppm (balance in air).	<120s
NG - Methane	0.6 - 0.8% BV (balance in air)	<30s
LPG - Liquid Petroleum Gas	0.3 – 0.4% BV (balance in air)	<30s
H - Hydrogen	5000 - 6000ppm (balance in air)	<30s
O ₂ - Oxygen	15% (balance in Nitrogen).	<60s

All certified test gases supplied by OGS are classified as non-flammable and non-toxic, however, they do contain gas under pressure and may explode if heated to extreme temperatures and cause asphyxiation in high concentrations.

How to perform a Bump Test?

1. Ensure you have the correct gas for the device type prior to application.
2. Screw and seal the regulator/valve into the gas cylinder outlet.
3. Once sealed, the regulator pressure gauge will indicate cylinder pressure.
4. Offer up the applicator hose/cone to the lower vents.
5. Open the valve/regulator to allow the gas to be delivered at a pre-set flow rate.
7. Wait for the device to enter alarm status and energise configured outputs/relays.
At this point...
9. Remove applicator hose/ cone and turn the gas cylinder regulator/valve off.
10. Wait for the device to return to normal.
11. Reset the system if required. Record your test details.

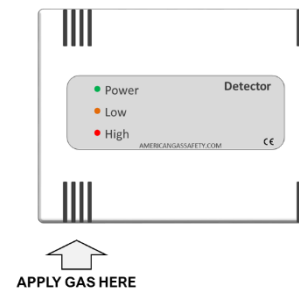

Notes:

To increase reaction time, cover the escape vents at the top of the device.
Alternatively, enclose the device and apply gas i.e. in an airtight bag or container.
For more help and advice on bump testing – contact us.



Always remove the regulator/valve from cylinder after use!

Always check cylinder pressure upon sealing valve – there may not be a sufficient amount of gas!

All OGS cylinders will re-seal upon removal of the regulator/valve!

Always give at least five (5) minutes between testing the same unit or until gas has fully dispersed!

Always consider safety and use equipment in accordance with Safety Data Sheets!

End of Operational Life (EOL)

The typical life of a gas detector depends on its application and intended target gas, in addition, the operational life can be prolonged if the system and equipment is installed and maintained in accordance the instructions stated within this manual.

- Natural Gas /Methane: 10 Years approx.
- Liquid Petroleum Gas: 10 Years approx.
- Hydrogen: 10 Years approx.
- Carbon Monoxide: 5 Years approx.

At the end of this time, contact your supplier and replace the unit immediately.

Specification

General								
Product:	Gas Detector							
Model(s):	CO (Carbon Monoxide) NG (Methane/Natural Gas) LPG (Liquid Petroleum Gas) H (Hydrogen) O2 (Oxygen)							
Use:	Indoor, Safe Areas (not to be used in potentially explosive atmospheres)							
Indicators (LED)	Green (Power), Yellow (Pre Alarm) & Red (Alarm).							
Mounting	Wall Mounting							
Electrical								
Max. Power Consumption	90mA Max @ 24vdc							
Power Voltage Input Range	12-32Vdc (24vdc Nominal)							
BMS Terminal	Volt Free (Normally Closed / Common / Normally Open)							
Relay(s)	0.5A Switching Current (Resistive Load)							
Terminal Wire ratings	Copper 18AWG (0.75mm ²) Min. 6x screw terminals.							
Construction								
Dimensions (H x W x D)	95.3 x 133 x 38mm / 3.75 x 5.23 x 1.5"							
Unit Weight (Approx.)	0.04kg / 1.41oz							
Housing Material	Polylac - PA765							
Environmental								
Ingress Protection	IP40							
Storage Conditions	Dry. Temp: -10 ~ 50°C / 14~ 122°F : 30 ~ 80% rh							
Compliance								
CE / UKCA	BS EN 50270 / BS EN 61010-1							
Sensor Specification								
Factory Calibration Conditions	25° ± 5°C - 77° ± 41°F (40-70% RH)							
Sensor Operating Temperature	-10C° ~ 50°C (14 ~ 122°F)							
Sensor Operating Humidity	Continuous 30-80% rh Non-Condensing							
Sensor Operating Pressure	Normal Atmospheric Pressure ± 10%							
Gas Sensor	Indicating Range	Steps	Calibration Gas	Response (t ₉₀)	Recovery (t ₁₀)	Alarm: 1 (Pre alarm warning)	Alarm: 2	*EOL (Years)
Electrochemical Sensors								
Carbon Monoxide (CO)	0-999ppm	N/A	120ppm CO	<60s	<60s	▲20ppm	Exposure time. ▲20ppm (after two hours) ▲50ppm (after one hour) ▲100ppm (after ten minutes) ▲300ppm (after one minute)	5
Oxygen (O ₂)	0-30% V/V	N/A	Clean Air (20.9%)	<30s	<60s	N/A	▼18.5% V/V ▲23% V/V	3
Semiconductor Sensors								
Methane (CH ₄)	0-20% LEL	N/A	0.5% BV methane	<30s	<30s	▲8% LEL	▲10% LEL	10
Propane (LPG)	0-20% LEL	N/A	0.2% BV Propane	<30s	<30s	▲8% LEL	▲10% LEL	10
Hydrogen (H)	0-20% LEL	N/A	4000ppm Hydrogen	<30s	<30s	▲8% LEL	▲10% LEL	10

▲ Rising Alarm ▼ Falling alarm

*EOL – Expected Operational Life

Page intentionally left blank

Page intentionally left blank

Installation Details

Please pass this manual to the system owner / user.

Date of Installation:	
Installation Location:	
Organisation:	
Stamp/Signature of the installer:	

We recommend all Merlin gas detection equipment be commissioned by competent/trained engineers to ensure correct installation and operation. The Merlin range of gas detectors are calibrated when manufactured, however, we strongly recommend the detectors response and alarm signals are tested and validated once installed. This will ensure the equipment performs as intended and is free from any unforeseen damage caused by transit/installation.

Every effort is made to ensure the accuracy of this document; however, Oceania Gas Safety can assume no responsibility for any errors or omissions in this document or their consequences. Oceania Gas Safety would greatly appreciate being informed of any errors or omissions that may be found in the content of this document. For information not covered in this document, or if there is a requirement to send comments/corrections, please contact Oceania Gas Safety using the contact details given below.

Oceania Gas Safety
info@oceaniagasafety.com
Tuakau, Waikato
New Zealand
+64212386990



Oceania Gas Safety is the owner of this document and reserves all rights of modification without prior notice.